

UDC 378.147:744

DOI: 10.52534/msu-pp.8(4).2022.66-72

**Olga V. Habovda\***

Mukachevo State University

89600, 26 Uzhgorodska Str., Mukachevo, Ukraine

## Teaching Descriptive Geometry, Engineering, and Computer Graphics in the Context of Rapid Development of Digital Production

**Article's History:**

Received: 20.08.2022

Revised: 25.11.2022

Accepted: 28.12.2022

**Suggested Citation:**

Habovda, O.V. (2022). Teaching descriptive geometry, engineering, and computer graphics in the context of rapid development of digital production. *Scientific Bulletin of Mukachevo State University. Series "Pedagogy and Psychology"*, 8(4), 66-72.

**Abstract.** The relevance of the study is due to the continuous development of automated design systems and global trends in the digital transformation of production at all levels of the product life cycle. Since one of the main principles of education is integration with science and production, this integration is the main condition for its further development and a factor in ensuring its quality. The product life cycle begins with project design, which students of technical specialities begin to master by studying descriptive geometry, engineering, and computer graphics. In this course, the skills of working in automated design systems are pawned, so its teaching should take place using updated technologies that the present needs. The purpose of the study is to analyse the experience of teaching graphic disciplines in higher educational institutions and to substantiate the methods of studying the discipline "Engineering and computer graphics" based on the author's experience, considering trends in the development of digital production. The research work was conducted using general scientific methods by analysing scientific-technical information on the subjects covered and using the method of pedagogical experiment. The study suggests using computer-aided design systems starting with the study of descriptive geometry, provides practical ways to solve classical problems of descriptive geometry by means of automated design systems, defines the minimum skills within the course to ensure further assimilation of the capabilities of automated design systems in special courses, during the implementation of course projects and to reduce the period of adaptation of the future specialist to professional activities. The practical importance of the research is in the development of a methodology for the transition from conventional methods of studying descriptive geometry, which involve the use of drawing tools, to modern ones using computer-aided design systems, which contributes to their accelerated mastering by students to further apply them in the study of technical disciplines

**Keywords:** latest technologies in production, automated design systems, computer modelling, innovative teaching methods, graphic disciplines

\*Corresponding author

### INTRODUCTION

Product design skills for students of technical specialities are pawned when studying descriptive geometry, engineering, and computer graphics, and it is from this course that students begin to master working in computer-aided design systems.

Due to the French researcher Gaspard Monge, who in the 18<sup>th</sup> century laid the foundations of descriptive geometry – the graphic language of all technology, proposing a method of the orthogonal projection of spatial objects on a plane, engineers got a solution for the image of projected products in drawings. Due to the AutoCAD system

released in 1982 by the American company Autodesk – the first CAD (Computer-Aided Design) – system for a personal computer, the designer replaced a drawing board with a computer.

Today, due to the rapid development of computer-aided design (CAD) systems, which contain not only tools for creating three-dimensional models and drawings, but also engineering analysis systems, product data management systems, etc. (for example, SolidWorks Simulation, SolidWorks Flow Simulation, SolidWorks Motion, and other SolidWorks software products), a modern constructor do

not use a computer as an electronic drawing board. They have the opportunity to create virtual three-dimensional models of parts and assemblies of the product, test it and individual parts and components for durability, endurance, and vibrations, simulate fluid flow, heat exchange, hydrodynamic forces, analyse the movement of links of mechanisms, and much more.

Tools such as parameterisation, which can be used to control the geometry of objects by establishing geometric and dimensional dependencies between them, and the ability to create associative drawings of three-dimensional models in which all types are associated with the model so that changes in the model lead to a change in the image in each associative form, and, conversely, changes in the drawings can change the model (in SolidWorks).

The emergence of modern CAD could not but affect the conventional methods of teaching descriptive geometry and computer engineering graphics, so the issues of graphic training of students are actively discussed in many scientific and pedagogical papers, the authors of which, agreeing that with the advent of 3D modelling made it necessary to change the methods, often express diametrically opposed opinions about these changes, especially in regard to teaching descriptive geometry.

The purpose of the study is to develop a methodology for teaching descriptive geometry and computer engineering graphics using CAD. An analysis of the experience of teaching graphic subjects in higher educational institutions was conducted, problems of graphic training of students were identified, and the methodology of teaching the discipline "Engineering and computer graphics" based on the author's experience was substantiated to achieve this goal.

The results of the analysis of scientific and methodological papers on the problem under study confirm its importance and the lack of unanimity of opinions on the methodology of teaching graphic disciplines.

An interesting idea about the classical name of the discipline is expressed by the authors of Yu.M. Kovaliov and V.M. Vereshchaha: "The consequence of the development of science and technology was the differentiation of requirements for geometric modelling, which ceased to be mainly graphic. Therefore, classical courses in descriptive geometry and engineering graphics are no longer sufficient for modern engineers or architects and should be supplemented with ideas and methods of computational geometry, multidimensional geometry, and systems theory. That is why the classical name is being changed to 'Applied geometry'. All these areas have a common theoretical basis – axiomatic models of space, the theory of transformations, and means of providing visibility..." [1]

Most Ukrainian researchers believe that teaching the section on descriptive geometry in the course of engineering and computer graphics should take place according to the conventional method using a drawing tool, and then in the section on engineering graphics – using computer technologies (2D and 3D modelling) [2]. Others believe that teaching using the most modern CAD systems

should start from the 1st semester, that is, with the section on descriptive geometry [3-5], including researchers from other countries. Spanish researchers R. Moreno of the University of Granada and A. Bazan of the Higher Technical School of Civil Engineers (Madrid), in their joint paper, expresses the following opinion: since drawing tools have changed dramatically in recent years, this has had implications for teaching descriptive geometry. CAD packages replace drawing manually. This has made the subject more interesting and attractive for students, as they can now create high-quality graphic works [6]. There is also a more radical approach, namely, the rejection of the study of descriptive geometry. Thus, the researcher V. Rukavishnikov in his paper [7] emphasises that "modern three-dimensional computer geometric models, having the properties of not only geometric but also mathematical and physical models, have acquired an integrative character. The dimensions of the model and the modelling object began to coincide, which removed many problems that previously had to be solved when creating geometric models using descriptive geometry technology."

According to researchers M.M. Kozyar and Z.K. Sasiuk, the educational process of studying the discipline in Ukrainian universities is well provided with textbooks, the authors of which are such researchers as V.E. Mikhailenko, V.M. Naydysh, V.Ya. Naumenko, V.H. Shevchenko, and others. "However, their content does not consider the present and does not give students the opportunity to master it perfectly. A scientific and pedagogical worker should focus on a scientifically based solution to the problems of improving and optimising the process of teaching descriptive geometry, considering trends in world technical education" [8].

Modern multimedia tools enable the creation of manuals with hyperlinks to illustrations, models of phenomena and devices in dynamics, etc. In European countries that have similar problems with teaching graphic disciplines, electronic textbooks have already existed for quite some time. For example, researchers from the University of Zagreb (Croatia) have created a textbook on descriptive geometry, where the presentation of classical content is implemented using information technologies and the introduction of 3D modelling. At the Krakow University of technology, descriptive geometry problems are solved using computers with AutoCAD software, and an e-learning platform with a full set of features. "The main task during training is to make the student realise that the computer can only do what the operator makes it, and it is necessary to have theoretical knowledge to be able to use it to solve a given problem" [9].

Since among the principles of education specified in the Law of Ukraine "On Education" [10], there are principles of the scientific nature of education and integration with the labour market, this integration is the main condition for further development and a factor in ensuring its quality. Digital production involves creating a design and technological environment for the simultaneous work of all participants in the production process with a single virtual electronic product model.

The originality of the research work lies in the application of computer-aided design systems in the study of descriptive geometry.

## MATERIALS AND METHODS

The study was conducted in several stages using general scientific methods, in particular, the analysis of scientific-technical information on this subject, comparison of alternative scientific opinions on the problem under study, synthesis, and systematisation of practical experience in the use of CAD in the process of teaching the discipline “Engineering and computer graphics” (ECG), the method of pedagogical experiment. The methodology of teaching the ECG discipline is understood as the organisation of the process of studying the discipline (a set of principles, content, methods, means, and forms).

In the first stage, based on the author’s previous study on the concepts of digital production, which require the introduction of complex systems of automation (CAS) of the CAD/CAM/CAE/CAPP/PLM/ERP class at Ukrainian enterprises [11], the requirements for graphic training of mechanical specialists during the entire period of study at the University were determined.

In the course of the study, attention was focused on the principles of continuity in learning, which would provide students with the necessary knowledge in the further development of technical disciplines that are in a structural and logical connection with the ECG discipline.

In the second stage, using the method of system analysis, scientific-pedagogical work on this subject and the experience of teaching graphic disciplines in higher educational institutions of Ukraine were analysed, controversial issues regarding teaching methods were considered, and difficulties that students will face at the beginning of studying graphic disciplines were noted.

In the third stage, a methodology for teaching engineering and computer graphics, which was tested at Mukachevo University, is proposed. The method of a pedagogical experiment was used, which was conducted in the laboratory of engineering and computer graphics using Kompas-3D CAD (in the near future – SolidWorks CAD). End-to-end use of CAD in the study of all sections of ECG is proposed. The rationale for the inexpediency of using a drawing tool in the study of descriptive geometry – the first section of the discipline is given. Examples of solving descriptive geometry problems using CAD are given.

## RESULTS AND DISCUSSION

In 2011, the Association of Industrial Automation of Ukraine of Ukraine (APPAU) was established, which aims to unite with the IT sector and high-tech communities and direct the general movement to accelerate the modernisation of Ukrainian production by introducing the latest technologies. Practitioners who train applicants for technical specialities should also contribute to this movement by providing up-to-date knowledge in the training of a valuable engineer. The result of this training is the acquisition of skills

in geometric modelling and product design (CAD-system), its engineering analysis (CAE-system), familiarisation with computer support systems for product manufacturing (CAM-system), technologies for product lifecycle management (PLM), etc., which will give confidence to the future specialist and accelerate their adaptation to professional activities.

“The era of drawings is a thing of the past. The world’s focus is on digital production technologies ...” [12]. The author fully agrees with this opinion. The problem with implementing PLM technology in Ukraine, among other things, is the rupture of the integrated “design – manufacturing” chain. It is the use of drawings that breaks this chain. This suggests a conclusion about the dispute between proponents of the study of descriptive geometry and their opponents: at least, as long as drawings are used, one should not abandon the study of descriptive geometry, because the ability to represent a spatial object from a two-dimensional image and, conversely, create a drawing from a spatial object is provided by descriptive geometry. Even if the drawing is generated automatically, it is the designer who decides how many forms the drawing should have, what sections and cross-sections are needed so that the part or product becomes fully defined and can be manufactured.

In addition to the fact that descriptive geometry is one of the disciplines that form the basis of engineering education, its study contributes to the development of spatial representation. Unfortunately, applicants for education who graduate from schools where, in the vast majority, they do not learn drawing, find it difficult to study descriptive geometry due to the insufficient development of spatial representation, without which it is impossible to become an engineer. The perception of educational information is problematic for 80% of students [13]. From the standpoint of psychology, they have an insufficiently developed right hemisphere of the brain, which is responsible for imaginative thinking. “The course of descriptive geometry is one of the few in the university that affects the development of the right hemisphere of the brain and compensates for the overload of the left hemisphere with information that comes from studying most other disciplines” [14].

The use of a drawing tool in the study of descriptive geometry in the present time is one of the factors that hinder the process of mastering the discipline. When drawing boards were removed from graphics labs, and computers were not yet a widely available tool, students switched to T-squares, but at that time they still knew how to use this tool, since they were still taught drawing at school. Nowadays, there is no need to draw manually.

The transition period has long ended, and engineering graphics laboratories are equipped with computers with installed software (at least AutoCAD or Compass Graphic), so the use of a computer in the study of graphic disciplines is logical and fully justifies itself.

This is what is stated in [15]: “...It is identified that today there are actually two components of the methodology for teaching engineering graphics: conventional and computer. Moreover, the transition period from conventional

engineering graphics to computer graphics is clearly traced. It is established that the disadvantage of the conventional methodological system of training engineering and graphic disciplines of future mechanical engineers is conservatism, non-compliance of the content of engineering and graphic training with the requirements of modern production and development of equipment and technologies. There is a typical situation of teaching engineering graphics with the dominance of reproductive teaching methods, limited scientific-methodological tools of an innovative nature, proper educational, and methodological support for the organisation of independent work. As a result, there is a noticeable tendentious decrease in academic aspirations and, accordingly, students' academic achievements, substantial difficulties in mastering academic subjects in engineering graphics."

Every year there is a reduction in the number of classroom classes. This fact makes it necessary to optimise the methodology for studying ECG. The use of CAD allows for accelerating the acquisition of the necessary skills. In addition, with the development of multimedia tools, the lecturer no longer uses blackboards and crayons. Lectures-presentations made in PowerPoint, demonstrations of building 3D models substantially increase visibility and are better perceived and assimilated by students. One of the advantages of using PowerPoint is that it is possible to divide the solution to a given problem into separate steps and gradually demonstrate them using various animations. To strengthen the motivation to study ECG, there is a need to find a place for periodic demonstration of the practical application of knowledge in product design and production from the first year when conducting lectures, as researchers suggest in the work [16]: "...Theoretical material from the course of technical drawing, in parallel with the explanations of the teacher, is periodically accompanied by a demonstration of educational presentations (video materials) aimed at familiarising students with technology and modern production, the design process... . This activates the mental activity of students, since they operate in the

imagination with spatial images of kinematic elements, comparing them with the corresponding symbolic (conventional) designations, reproducing basic information in memory, modelling the dynamics of their work."

The author believes that to optimise the subject of practical work, it is possible to reduce the execution of con-jugations and other geometric constructions, leaving them only in lectures, since CAD tools perform these constructions easily and are almost unrelated to conventional construction methods. Familiarisation with the methods of axonometric representation of objects is also proposed to be conducted only in lectures since the construction of axonometric images manually takes students a lot of time, which is not enough to perform current tasks, and axonometric views are also automatically generated on drawings if necessary.

When performing tasks in descriptive geometry at Mukachevo University, the computer is used only as an electronic drawing board. Students quickly master working in the Compass-3D environment, as the work requires the ability to use only three panels: "Geometry", "Editing" and "Annotation". A separate lecture is not necessary to get these skills: it is possible to learn everything in practice. In addition, students use the developed laboratory workshop on ECG (in 2 parts), which provides a step-by-step sequence of completing tasks. As a type of electronic document, "Fragment" is used – an auxiliary type of graphic document that is characterised by the absence of a frame, main label, and other document design objects. When using CAD, precise lines (parallel, perpendicular, and at any angle) are easily constructed, which is difficult to achieve manually. In addition, the dimensions are precisely set, which eliminates errors. Relative to the curves of the intersection lines of surfaces, they are constructed with sufficient reliability from the obtained points using the "Spline by points" tool of the "Geometry" panel.

Examples of solving problems in descriptive geometry using Kompas-3D and SolidWorks CAD are shown in Figures 1 and 2.

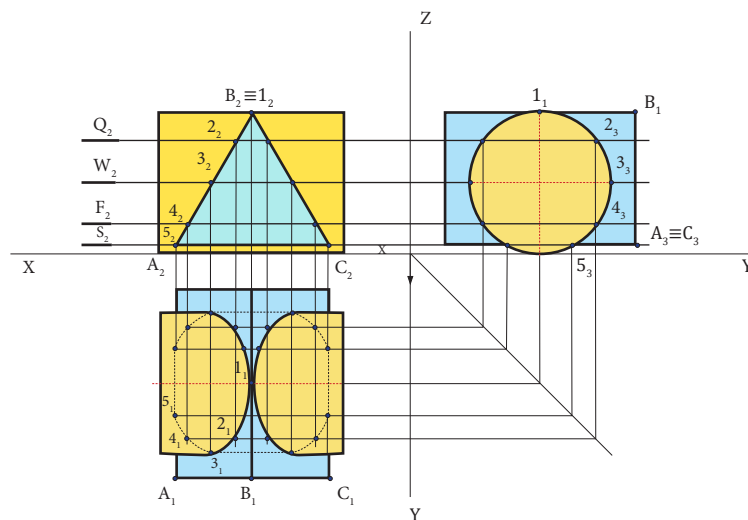

**Figure 1.** Solution of the problem of constructing lines of intersection of a cylinder and a prism in CAD Compass 3D  
**Source:** developed by the authors based on their own examination

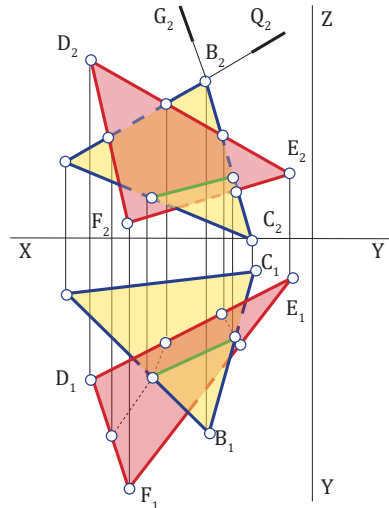

**Figure 2.** Solving the problem of constructing a line of intersection of two planes in SolidWorks CAD

**Source:** developed by the authors based on their own examination

In the engineering graphics section for mastering the subject “Projection drawing. Forms, cuts, cross-sections” and “Threads. Threaded connections” students use 2D modelling, working in an electronic document “Sketch”. After mastering this material, the student is considered prepared for 3D modelling and gets acquainted with the structure of parametric models of parts and assemblies, based on which working drawings of parts and assembly drawings are generated, followed by the creation of an electronic specification in manual mode or with automatic filling in of the specification with basic objects connected to it.

When drawing up the work programme on ECG, the principle of continuity in training is guiding, that is, the subject of the discipline is coordinated with the subject of disciplines that should be provided by ECG. These disciplines include an in-depth study of design and modelling in CAD/CAM/CAE systems, classical disciplines – theory of mechanisms, machines, and machine parts (to ensure the implementation of course projects), and specialised design disciplines. Considering this, the ECG discipline plays an important role in ensuring the principle of continuity and consistency of training throughout the entire training period.

Evidently, in the ECG course, an education applicant should learn the theoretical foundations of designing spatial objects, get acquainted with the standards of the unified system of design documentation, get a concept of connections, learn to read, and perform assembly drawings, fulfil specifications, know the requirements for working drawings of parts, while performing all practical tasks using CAD. The student, already in the framework of this course, masters the basic operations of building 3D models with subsequent automatic generation of associative drawings on them, learns to perform simple 3D models of assemblies.

Further study of ECG is planned using SolidWorks CAD as a system with more advanced functions, the presence of many modules and as a CAD widely used in machine-building design organisations, enterprises, and

senior courses in the study of computer design and modelling. In general, the author supports the opinion that it is advisable to master one of the most modern computer-aided design systems in-depth (within the capabilities of the university) in all special courses related to design, engineering analysis, and technological preparation of production, which contains the necessary functional modules. By focusing on working in a single system, students have the opportunity to learn CAD tools more deeply. However, there is another opinion. The authors [17] believe that “to create favourable conditions for successful professional and graphic training of a future CAD specialist, it is important to ensure the organisation of a perfect educational process in engineering and computer graphics based on the integration of graphic software products, such as AutoCAD and SolidWorks.” When choosing CAD systems, it is advisable to have information about which of them are used at the most modern enterprises in the region – potential places of employment for future specialists.

## CONCLUSIONS

The study explained how it is proposed to solve problems of descriptive geometry using CAD, and what minimum skills, according to the author, students should get in the framework of the ECG course to move forward in familiarising themselves with the huge opportunities of modern CAD and acquiring skills of their application both in the implementation of course projects in the learning process and in future engineering activities.

Teaching the discipline “Engineering and computer graphics” should be innovative, considering the global trends in the development of digital production, since with it the development of computer-aided design systems begins, without the assimilation of which the future specialist will not be able to quickly adapt to their professional activities and be competitive in the labour market.

The innovative nature of teaching should take place through the use of multimedia computer tools during lectures

and the end-to-end use of CAD when students perform practical tasks, starting with descriptive geometry, and independent processing of materials presented in electronic textbooks with available hyperlinks to interactive illustrations. Such innovative methods are used in world practice. Therewith, the interdisciplinary connection of ECG with professionally oriented academic disciplines should be considered, which contributes to the conscious assimilation of the necessary knowledge, motivates the student to study, and also focuses on the connection of the ECG course with technology and modern production.

As the research results have shown, the introduction of CAD in the educational process, starting with descriptive geometry, has a positive effect on students' perception and

assimilation of geometric modelling skills, contributes to the development of spatial thinking, and improves training for further mastering of CAD in the study of disciplines that should be provided by ECG. It is advisable to coordinate the choice of CAD systems with the trends of their development at the most modern enterprises in the region – potential places of employment for future specialists. End-to-end application of the entire CAD package allows future specialists to get acquainted with the production process throughout the entire product life cycle and prepare for competition in the labour market.

The possibilities of end-to-end implementation of computer-aided design systems in specialised courses throughout the entire learning process are a prospect for further research by the author.

## REFERENCES

- [1] Kovaliov, Yu.M., & Vereshchaha, V.M. (2012). *Applied geometry: Descriptive geometry, engineering and computer graphics, modern sections*. Kyiv: Omeha-L.
- [2] Matsiuk, I.M., Savelieva, T.S., & Pustovoi, D.S. (2020). Teaching engineering graphics using modern information technologies. *Prosperity and reach of applied and fundamental sciences of the XXI century: Materials of the international scientific conference* (Vol. 2; pp. 37-41). Cherkasy: MCND. doi: 10.36074/07.08.2020.v2.07.
- [3] Raikovska, H.O., & Solovyov, A.V. (2019). CAD in graphic training. *Scientific Bulletin of Uzhhorod University. Series: "Pedagogy. Social Work"*, 2, 149-153. doi: 10.24144/2524-0609.2019.45.149-153.
- [4] Chepok, R.V. (2013). New opportunities for solving geometric problems using Compass 3dv10 in the process of teaching engineering and computer graphics with a workshop. *Collection of Scientific Papers of Uman State Pedagogical University*, 3, 331-337. doi: 10.31499/2307-4906.0.2013.197680.
- [5] Znamerovska, N.P., & Kravtsova, L.V. (2019). Application of practical experience at preparatory of specialists in the marine sector: Use of information and communication technologies for the study of graphical disciplines. *Lógos. The Art of Scientific Mind. Country*, 4, 76-80.
- [6] Moreno, R., & Bazán, A. (2017). Automation in the teaching of descriptive geometry and CAD. High-level CAD templates using script languages. *IOP Conference Series: Materials Science and Engineering*, 245(6), article number 062040. doi: 10.1088/1757-899X/245/6/062040.
- [7] Rukavishnikov, V.A. (2009). Geometry and graphical engineer training: Part and place in educational system. *Education and Sciencel*, 5, 32-37.
- [8] Kozyar, M.M., & Sasiuk, Z.K. (2015). Modern educational tendencies and problems of teaching of a sketch geometry in higher educational establishments. *Scientific Journal of M. P. Dragomanov National Pedagogical University. Series 5 Pedagogical Sciences: Realities and Perspectives*, 52, 113-121.
- [9] Vogt, B. (2015). AUTOCAD and e-learning in teaching descriptive geometry. *Technical transactions. Architectur*, 11-A, 53-62.
- [10] Law of Ukraine No. 2145-VIII "On Education". (2017, September). Retrieved from <https://zakon.rada.gov.ua/laws/show/2145-19#Text>.
- [11] Habovda, O.V., & Sadovnikova, T.M. (2018). Analysis of complex systems of automation in machine-building and implementation them in Ukraine. *Education and Science*, 1, 9-15.
- [12] Raikovska, H.O. (2019). Ways to improve the training of specialists in the machine-building industry. *Visnyk of Vinnytsia Polytechnical Institute*, 2, 111-116. doi: 10.31649/1997-9266-2019-143-2-111-116.
- [13] Kozyar, M. (2016). Descriptive geometry at the turn of the century. *Youth and Market*, 3, 22-27.
- [14] Vanin, V.V., & Hnitetska, H.O. (2017). Psycho-physiological aspects of graphic information. In *Collection of reports of the 6<sup>th</sup> All-Ukrainian scientific and practical conference of students, postgraduates and young scientists "Applied geometry, design, objects of intellectual property and innovative activity of students and young scientists"* (pp. 56-58). Kyiv: National Technical University of Ukraine "Igor Sikorsky Kyiv Polytechnic Institute".
- [15] Boiko, V.A. (2019). *Methodology of training the engineering graphics of the future engineers-mechanics by means of computer modeling* (PhD thesis, National Pedagogical Dragomanov University, Kyiv, Ukraine).
- [16] Nyshchak, I., Martynets, L., Kurach, M., Buchkivska, G., Greskova, V., & Nosovets, N. (2020). Didactic opportunities of information and communication technologies in graphic training of future technology teachers. *Brain Broad Research in Artificial Intelligence and Neuroscience*, 11(2), 104-123. doi: 10.18662/brain/11.2/77.
- [17] Kozyar, M., Sasiuk, Z., & Parfeniuk, O. (2018). Graphic training of the future specialist by means of CAD. *New Pedagogical Thought*, 2, 122-126.

**Ольга Веніамінівна Габовда**

Мукачівській державний університет  
89600, вул. Ужгородська, 26, м. Мукачево, Україна

## **Викладання нарисної геометрії, інженерної і комп'ютерної графіки в умовах стрімкого розвитку цифрового виробництва**

**Анотація.** Актуальність статті зумовлено невідомим розвитком систем автоматизованого проектування та світовими тенденціями цифрової трансформації виробництва на всіх рівнях життєвого циклу виробу. Оскільки один з основних принципів освіти – інтеграція з наукою і виробництвом, ця інтеграція є головною умовою її подальшого розвитку та фактором забезпечення її якості. Життєвий цикл виробу починається з проектування, опановувати яке студенти технічних спеціальностей починають з вивчення нарисної геометрії, інженерної та комп'ютерної графіки. Саме в цьому курсі закладаються навички роботи в системах автоматизованого проектування, тому його викладання має відбуватися за оновленими технологіями, яких потребує сьогодення. Метою роботи є аналіз досвіду викладання графічних дисциплін у вищих навчальних закладах, а також обґрунтування методів вивчення дисципліни «Інженерна і комп'ютерна графіка» на основі власного досвіду автора з урахуванням тенденцій розвитку цифрового виробництва. Дослідження проводилися із застосуванням загальнонаукових методів шляхом аналізу науково-технічної інформації за порушеною тематикою та методом педагогічного експерименту. У статті запропоновано використовувати системи автоматизованого проектування починаючи з вивчення нарисної геометрії, надаються надано практичні способи розв'язання класичних задач нарисної геометрії засобами систем автоматизованого проектування, визначено мінімальні навички в межах курсу для забезпечення подальшого засвоєння можливостей систем автоматизованого проектування в спеціальних курсах, під час виконання курсових проектів та для скорочення терміну адаптації майбутнього фахівця до професійної діяльності. Практичне значення дослідження полягає в розробці методики переходу від традиційних методів вивчення нарисної геометрії, що передбачають застосування креслярських інструментів, до сучасних з використанням систем автоматизованого проектування, що сприяє їхньому прискореному опануванню студентами з метою подальшого застосування при вивченні технічних дисциплін

**Ключові слова:** новітні технології в промисловості, системи автоматизованого проектування, комп'ютерне моделювання, інноваційні методики викладання, графічні дисципліни